

Intercomp[®]

advanced weighing technology ... by any measure



The Axle Weighing Specialist



Portable Static Wheel/Axle Scales

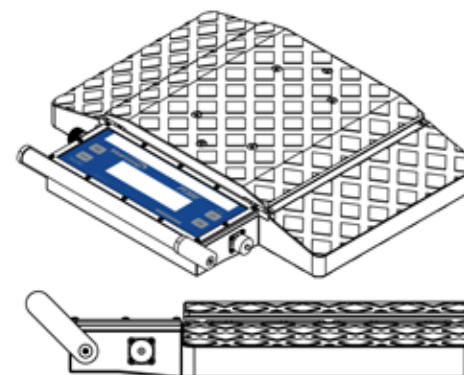

Pad Dimensions: 12" x 12" x 3" (305 x 305 x 76 mm)
Overall Dimensions: 16" x 20" (406 x 508 mm)



PT300 Scale Pads

PART #	DESCRIPTION	CAPACITY/GRADUATION	SHIPPING WEIGHT
181006-RFX	PT300 WIRELESS SOLAR WHEEL LOAD SCALE (5K X 5)	5,000 X 5 LB (2,500 X 2 KG)	41 LB (19 KG)
181005-RFX	PT300 WIRELESS SOLAR WHEEL LOAD SCALE (10K X 5)	10,000 X 5 LB (5,000 X 2 KG)	41 LB (19 KG)
181004-RFX	PT300 WIRELESS SOLAR WHEEL LOAD SCALE (20K X 10)	20,000 X 10 LB (10,000 X 5 KG)	41 LB (19 KG)
181007-RFX	PT300 WIRELESS SOLAR WHEEL LOAD SCALE (20K X 20)	20,000 X 20 LB (10,000 X 10 KG)	41 LB (19 KG)
181008-RFX	PT300 WIRELESS SOLAR WHEEL LOAD SCALE (20K X 50) NTEP CLASS III	20,000 X 50 LB (10,000 X 25 KG)	41 LB (19 KG)
181013-RFX	PT300 WIRELESS SOLAR WHEEL LOAD SCALE (25K X 20)	25,000 X 20 LB (10,000X10 KG)	41 LB (19 KG)

NTEP 90-106PA3

PT300 Scale Systems (System Includes Scales, Case, HH60 Indicator, Charging Cable and Interconnect Cable)

PART #	DESCRIPTION	CAPACITY/GRADUATION	SHIPPING WEIGHT
181021-RFX	PT300 WIRELESS SOLAR WHEEL LOAD 2 SCALE SYSTEM (20K X 10)	40,000 X 10 LB (20,000 X 5 KG)	128 LB (67 KG)
181020-RFX	PT300 WIRELESS SOLAR WHEEL LOAD 2 SCALE SYSTEM (20K X 20)	40,000 X 20 LB (20,000 X 10 KG)	128 LB (67 KG)
181041-RFX	PT300 WIRELESS SOLAR WHEEL LOAD 4 SCALE SYSTEM (20K X 10)	80,000 X 10 LB (40,000 X 5 KG)	227 LB (103 KG)
181040-RFX	PT300 WIRELESS SOLAR WHEEL LOAD 4 SCALE SYSTEM (20K X 20)	80,000 X 20 LB (40,000 X 10 KG)	227 LB (103 KG)
181061-RFX	PT300 WIRELESS SOLAR WHEEL LOAD 6 SCALE SYSTEM (20K X 10)	120,000 X 10 LB (60,000 X 5 KG)	335 LB (152 KG)
181060-RFX	PT300 WIRELESS SOLAR WHEEL LOAD 6 SCALE SYSTEM (20K X 20)	120,000 X 10 LB (60,000 X 10 KG)	335 LB (152 KG)

PT300 Scale Accessories

PART #	DESCRIPTION	SHIPPING WEIGHT
100047	2 SCALE CARRYING CASE FOR PT300	41 LB (19 KG)
100048	4 SCALE CARRYING CASE FOR PT300	58 LB (26 KG)
100049	6 SCALE CARRYING CASE FOR PT300	84 LB (38 KG)
100070	PT300 RAMP - 2.68" X 12.70" X 11.44" (68 X 323 X 291 MM) - EXTERNAL RAMP W/2-PINS (EACH)	5 LB (2 KG)
100088	DUMMY PAD FOR PT300 SCALES	26 LB (12 KG)
100480	CHARGER FOR WHEEL LOAD SCALE (1 SCALE UNIVERSAL) 100-240 VAC - 12" (3.5 M)	2 LB (1 KG)
100492	CHARGER FOR WHEEL LOAD SCALE (2 SCALE UNIVERSAL) 100-240 VAC - 12" (3.5 M)	2 LB (1 KG)
100493	CHARGER FOR WHEEL LOAD SCALE (4 SCALE UNIVERSAL) 100-240 VAC - 12" (3.5 M)	3 LB (1 KG)
100494	CHARGER FOR WHEEL LOAD SCALE (6 SCALE UNIVERSAL) 100-240 VAC - 12" (3.5 M)	3 LB (1 KG)
330158	BATTERY STICK (4) AA NIMH	2 LB (1 KG)
750501	CERTIFICATE OF CALIBRATION	



Accuracy of ±1% of Reading

Available in Capacities to 25,000 lb (11,300 kg) per Pad

Large LCD Display with Backlight for Easy Readings from Scales

Rugged, Lightweight Aluminum Construction Built to Withstand Heavy Use; Ideal for Unimproved Surfaces

Rechargeable AA NiMH Batteries Included (4 per Scale)
Solar Power Provides up to One Year of Battery Life with Daytime, Outdoor Use (Up to 250 Hours without Solar Power)

Integrated Indicator with Comprehensive Push Button Controls Include: On/Off, Local/Total, Zero & Print/Accum

Self-Contained, High-Capacity Portable Wheel Load Scales

PT300™ scales have set the bar for portable, self-contained, compact wheel load scales for decades. Used to maximize legal payloads and reduce maintenance due to overload stress on equipment, these all-aluminum, fully-equipped electronic scales are capable of weighing up to 25,000 lb (11,300 kg) with an accuracy of ± 1%. Each scale features RFX® Wireless Weighing communication between scales and remote indicators and solar charging panels that virtually eliminate the need to manually recharge batteries between uses. PT300™ scales can also weigh dual-tire configurations by placing the scales under the outside tires, with the inside tires suspended in the air.

Compatible with a variety of Intercomp devices, see pages 12.



Wheel Load Scales

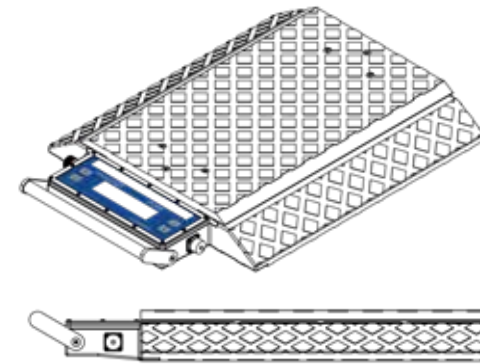

Pad Dimensions: 14" x 22" x 3" (356 x 559 x 76 mm)
Overall Dimensions: 20" x 26" (508 x 660 mm)



IP67 Protection

Accuracy of ±1% of Reading

Available in Capacities to 40,000 lb (20,000 kg) per Pad

Large LCD Display with Backlight for Easy Readings from Scales

Rugged Aluminum Construction Built to Withstand Heavy Use; Ideal for Unimproved Surfaces

Rechargeable AA NiMH Batteries Included (4 per Scale)

Solar Power Provides up to One Year of Battery Life with Daytime, Outdoor Use (Up to 250 Hours without Solar Power)

Integrated Indicator with Comprehensive Push Button Controls Include: On/Off, Local/Total, Zero & Print/Accum

Self-Contained, High-Capacity Portable Wheel Load Scales

Built with the same technology as standard PT300™ scales, PT300DW™ scales are wider to accommodate dual or super-single tires and are available in capacities up to 40,000 lb (20,000 kg). Standard features include rugged all-aluminum construction with accuracy of ±1%, RFX® Wireless Weighing, built-in solar charging panels, and IP67 Protection.

Compatible with a variety of Intercomp devices, see pages 12.

PT300DW Scale Pads

PART #	DESCRIPTION	CAPACITY/GRADUATION	SHIPPING WEIGHT
181506-RFX	PT300DW WIRELESS SOLAR WHEEL LOAD SCALE (5K X 5)	5,000 X 5 LB (2,500 X 2 KG)	62 LB (28 KG)
181505-RFX	PT300DW WIRELESS SOLAR WHEEL LOAD SCALE (10K X 5)	10,000 X 5 LB (5,000 X 2 KG)	62 LB (28 KG)
181504-RFX	PT300DW WIRELESS SOLAR WHEEL LOAD SCALE (20K X 10)	20,000 X 10 LB (10,000 X 5 KG)	62 LB (28 KG)
181503-RFX	PT300DW WIRELESS SOLAR WHEEL LOAD SCALE (20K X 20)	20,000 X 20 LB (10,000 X 10 KG)	62 LB (28 KG)
181501-RFX	PT300DW WIRELESS SOLAR WHEEL LOAD SCALE (30K X 50)	30,000 X 50 LB (15,000 X 25 KG)	62 LB (28 KG)
181502-RFX	PT300DW WIRELESS SOLAR WHEEL LOAD SCALE (40K X 100)	40,000 X 100 LB (20,000 X 50 KG)	62 LB (28 KG)

PT300DW Scale Systems (System Includes Scales, Case, HH60 Indicator, Charging Cable and Interconnect Cable)

PART #	DESCRIPTION	CAPACITY/GRADUATION	SHIPPING WEIGHT
181521-RFX	PT300DW WIRELESS SOLAR WHEEL LOAD 2 SCALE SYSTEM (20K X 10)	40,000 X 10 LB (20,000 X 5 KG)	239 LB (109 KG)
181520-RFX	PT300DW WIRELESS SOLAR WHEEL LOAD 2 SCALE SYSTEM (20K X 20)	40,000 X 20 LB (20,000 X 10 KG)	239 LB (109 KG)
181541-RFX	PT300DW WIRELESS SOLAR WHEEL LOAD 4 SCALE SYSTEM (20K X 10)	80,000 X 10 LB (40,000 X 5 KG)	344 LB (156 KG)
181540-RFX	PT300DW WIRELESS SOLAR WHEEL LOAD 4 SCALE SYSTEM (20K X 20)	80,000 X 20 LB (40,000 X 10 KG)	344 LB (156 KG)
181561-RFX	PT300DW WIRELESS SOLAR WHEEL LOAD 6 SCALE SYSTEM (20K X 10)	120,000 X 10 LB (60,000 X 5 KG)	493 LB (156 KG)
181560-RFX	PT300DW WIRELESS SOLAR WHEEL LOAD 6 SCALE SYSTEM (20K X 20)	120,000 X 20 LB (60,000 X 10 KG)	493 LB (156 KG)

PT300DW Scale Accessories

PART #	DESCRIPTION	SHIPPING WEIGHT
100050	2 SCALE CARRYING CASE FOR PT300DW	70 LB (32 KG)
100051	4 SCALE CARRYING CASE FOR PT300DW	91 LB (41 KG)
100052	6 SCALE CARRYING CASE FOR PT300DW	116 LB (53 KG)
100072	PT300DW RAMP - 2.68" X 22.88" X 11.44" (68 X 581 X 291 MM) - EXTERNAL RAMP W/2-PINS (EACH)	9 LB (4 KG)
100088	DUMMY PAD FOR PT300 SCALES- FOR USE WITH PT300DW	26 LB (12 KG)
100480	CHARGER FOR WHEEL LOAD SCALE (1 SCALE UNIVERSAL) 100-240 VAC - 12" (3.5 M)	2 LB (1 KG)
100492	CHARGER FOR WHEEL LOAD SCALE (2 SCALE UNIVERSAL) 100-240 VAC - 12" (3.5 M)	2 LB (1 KG)
100493	CHARGER FOR WHEEL LOAD SCALE (4 SCALE UNIVERSAL) 100-240 VAC - 12" (3.5 M)	3 LB (1 KG)
100494	CHARGER FOR WHEEL LOAD SCALE (6 SCALE UNIVERSAL) 100-240 VAC - 12" (3.5 M)	3 LB (1 KG)
330158	BATTERY STICK (4) AA NIMH	2 LB (1 KG)
750501	CERTIFICATE OF CALIBRATION	





Integrated Ramps for Ease of Approach



Accuracy of ±1% of Reading

Available in Capacities to 30,000 lb (15,000 kg) per Pad

Large LCD Display with Backlight for Easy Readings from Scales

Low-Profile Height of 1.5" (38 mm) for 5K, 10K or 20K Scales
1.7" (43 mm) for 30K Scales

Rechargeable AA NiMH Batteries Included (4 per Scale)
Solar Power Provides up to One Year of Battery Life with Daytime, Outdoor Use (Up to 250 Hours without Solar Power)

Integrated Indicator with Comprehensive Push Button Controls Include:
On/Off, Local/Total, Zero & Print/Accum

Low-Profile, Lightweight Digital Wheel Load Scales

Weighing 51 lb (23 kg) with a profile of just 1.5" (38 mm), the LP600™ Low-Profile Wheel Load Scale Family weighs loads up to 30,000 lb (15,000 kg) with an accuracy of ± 1%. They also feature fully-integrated RFX® Wireless Weighing Technology making it possible to sequentially couple and number scales, as well as link them to a multitude of Intercomp weighing indicators. Built-in solar charging panels virtually eliminate the need to manually recharge batteries between uses.

Compatible with a variety of Intercomp devices, see pages 12.

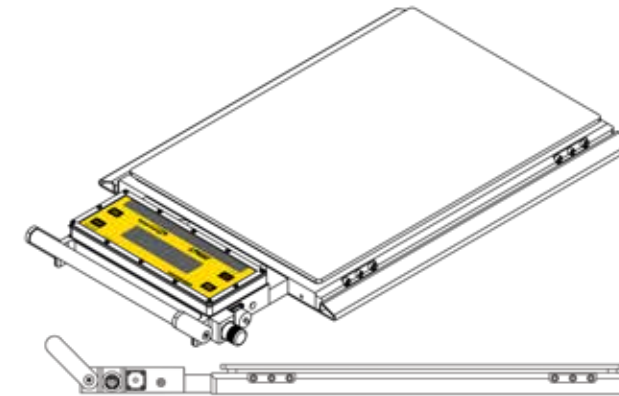

- LP600™ Pad Dimensions: 15" x 22.5" x 1.5" (381 x 569 x 38 mm)
Overall Dimensions: 18.5" x 33.25" (470 x 845 mm)
- LP630™ Pad Dimensions: 15" x 30" x 1.7" (381 x 762 x 43 mm)
Overall Dimensions: 18.5" x 40.3" (470 x 1024 mm)



LP600 Scale Pads

PART #	DESCRIPTION	CAPACITY/GRADUATION	SHIPPING WEIGHT
182008-RFX	LP600 WIRELESS SOLAR WHEEL LOAD SCALE (5K X 5)	5,000 X 5 LB (5,000 X 2 KG)	54 LB (24 KG)
182007-RFX	LP600 WIRELESS SOLAR WHEEL LOAD SCALE (10K X 5)	10,000 X 5 LB (5,000 X 2 KG)	54 LB (24 KG)
182006-RFX	LP600 WIRELESS SOLAR WHEEL LOAD SCALE (20K X 10)	20,000 X 10 LB (10,000 X 5 KG)	54 LB (24 KG)
182004-RFX	LP600 WIRELESS SOLAR WHEEL LOAD SCALE (20K X 20)	20,000 X 20 LB (10,000 X 10 KG)	54 LB (24 KG)
182018-RFX	LP600 WIRELESS SOLAR WHEEL LOAD SCALE (20K X 50) NTEP CLASS III	20,000 X 50 LB (10,000 X 25 KG)	54 LB (24 KG)
182015-RFX	LP600 WIRELESS SOLAR WHEEL LOAD SCALE (30K X 50)	30,000 X 50 LB (15,000 X 25 KG)	54 LB (24 KG)
182011-RFX	LP630 WIRELESS SOLAR WHEEL LOAD SCALE NO RAMPS (30K X 50)	30,000 X 50 LB (15,000 X 25 KG)	78 LB (35 KG)

NTEP 00-091PA3

LP600 Scale Systems (System Includes Scales, Case, HH60 Indicator, Charging Cable and Interconnect Cable)

PART #	DESCRIPTION	CAPACITY/GRADUATION	SHIPPING WEIGHT
182021-RFX	LP600 WIRELESS SOLAR WHEEL LOAD 2 SCALE SYSTEM (20K X 10)	40,000 X 10 LB (20,000 X 5 KG)	193 LB (88 KG)
182020-RFX	LP600 WIRELESS SOLAR WHEEL LOAD 2 SCALE SYSTEM (20K X 20)	40,000 X 20 LB (20,000 X 10 KG)	193 LB (88 KG)
182041-RFX	LP600 WIRELESS SOLAR WHEEL LOAD 4 SCALE SYSTEM (20K X 10)	80,000 X 10 LB (40,000 X 5 KG)	333 LB (151 KG)
182040-RFX	LP600 WIRELESS SOLAR WHEEL LOAD 4 SCALE SYSTEM (20K X 20)	80,000 X 20 LB (40,000 X 10 KG)	333 LB (151 KG)
182061-RFX	LP600 WIRELESS SOLAR WHEEL LOAD 6 SCALE SYSTEM (20K X 10)	120,000 X 10 LB (60,000 X 5 KG)	479 LB (217 KG)
182060-RFX	LP600 WIRELESS SOLAR WHEEL LOAD 6 SCALE SYSTEM (20K X 20)	120,000 X 20 LB (60,000 X 10 KG)	479 LB (217 KG)

LP600 Scale Accessories

PART #	DESCRIPTION	SHIPPING WEIGHT
101025	2 SCALE CASE FOR LP600 SCALES	80 LB (36 KG)
101039	4 SCALE CASE FOR LP600 SCALES	112 LB (51 KG)
101044	6 SCALE CASE FOR LP600 SCALES	150 LB (68 KG)
170118-R	DUMMY PAD FOR LP600 SCALES	34 LB (15 KG)
100480	CHARGER FOR WHEEL LOAD SCALE (1 SCALE UNIVERSAL) 100-240 VAC - 12" (3.5 M)	2 LB (1 KG)
100492	CHARGER FOR WHEEL LOAD SCALE (2 SCALE UNIVERSAL) 100-240 VAC - 12" (3.5 M)	2 LB (1 KG)
100493	CHARGER FOR WHEEL LOAD SCALE (4 SCALE UNIVERSAL) 100-240 VAC - 12" (3.5 M)	3 LB (1 KG)
100494	CHARGER FOR WHEEL LOAD SCALE (6 SCALE UNIVERSAL) 100-240 VAC - 12" (3.5 M)	3 LB (1 KG)
330158	BATTERY STICK (4) AA NIMH	2 LB (1 KG)
750501	CERTIFICATE OF CALIBRATION	



Wheel Load Scales

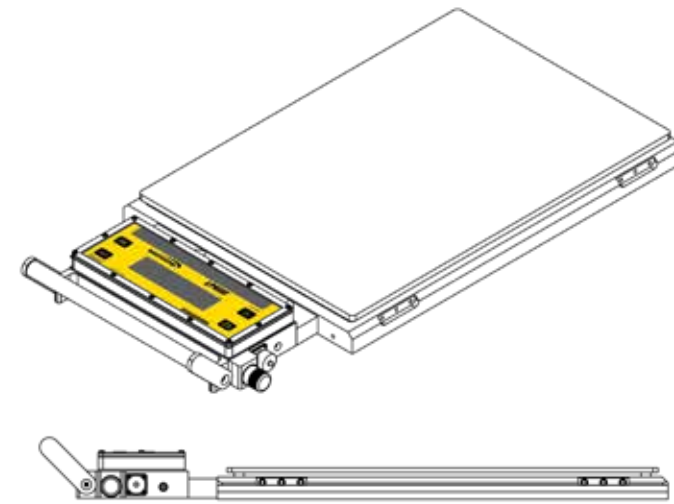

- LP600-10T™ Pad Dimensions: 22" x 15" x 1.5" (559 x 381 x 38 mm)
Overall Dimensions: 33.25" x 16" (845 x 406 mm)
- LP600-15T™ Pad Dimensions: 22" x 15" x 1.7" (559 x 381 x 43 mm)
Overall Dimensions: 33.25" x 16" (845 x 406 mm)
- LP630-15T™ Pad Dimensions: 30" x 15" x 1.7" (762 x 381 x 43 mm)
Overall Dimensions: 40.30" x 16" (845 x 406 mm)



Accuracy of ±1% of Reading

Available in System Capacities to 60,000 lb (30,000 kg)

Large LCD Display with Backlight for Easy Readings from Scales

Low-Profile Height of
1.5" (38 mm) for 20K Scales
1.7" (43 mm) for 30K Scales

Rechargeable AA NiMH Batteries Included (4 per Scale)
Solar Power Provides up to One Year of Battery Life with Daytime, Outdoor Use (Up to 250 Hours without Solar Power)

Integrated Indicator with Comprehensive Push Button Controls Include:
On/Off, Local/Total, Zero & Print/Accum

Ramps/Levelers Roll Up for Easy Transport

Portable Weighing Solution for Checkweighing & Compliance

The LP600-15T™ system weighs axle-by-axle in static mode, using just two scales, while extension levelers keep axle groups on a level plane, providing ±1% accuracy. The system is ideal for customers weighing heavy vehicles on improved surfaces. It can be transported in the back of a vehicle and set up by one or two people in under 15 minutes.

Includes:

- 2 Low-Profile Static Scales
- 4 Roll-Up Leveling Mats
- 2-Scale Universal Charger

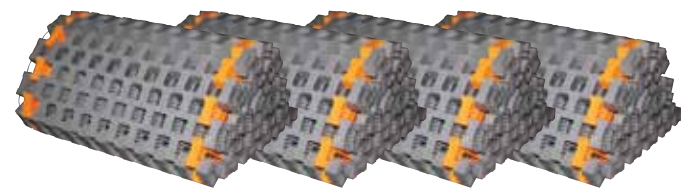

Compatible with a variety of Intercomp devices, see pages 12.

LP600-15T Scale Systems (Includes 2 Scales & 4 Roll-Up Ramps/ Levelers)

PART #	DESCRIPTION	CAPACITY/GRADUATION	SHIPPING WEIGHT
182019-RFX	LP600-10T WIRELESS SOLAR WHEEL LOAD SCALE SYS (20K X 50) NTEP CLASS III	40,000 X 50 LB (20,000 X 20 KG)	368 LB (167 KG)
182012-RFX	LP630-15T WIRELESS SOLAR WHEEL LOAD SCALE SYS (30K X 50)	60,000 X 50 LB (30,000 X 20 KG)	456 LB (207 KG)
182013-RFX	LP600-15T WIRELESS SOLAR WHEEL LOAD SCALE SYS (30K X 50)	60,000 X 50 LB (30,000 X 20 KG)	368 LB (167 KG)

NTEP 00-091PA3

LP600-15T Scale Accessories

PART #	DESCRIPTION	SHIPPING WEIGHT
101025	2 SCALE CASE FOR LP600 SCALES (NOT COMPATIBLE WITH LP630 SCALES)	80 LB (36 KG)
101039	4 SCALE CASE FOR LP600 SCALES (NOT COMPATIBLE WITH LP630 SCALES)	112 LB (51 KG)
101044	6 SCALE CASE FOR LP600 SCALES (NOT COMPATIBLE WITH LP630 SCALES)	150 LB (68 KG)
160165	ROLL-UP MATS FOR LP630 - SET OF 4 - 33.5" X 118" X 1.5" (850 X 3,000 X 40 MM)	348 LB (158 KG)
160168	ROLL-UP MATS FOR LP600 - SET OF 4 - 23.5" X 118" X 1.5" (600 X 3,000 X 40 MM)	260 LB (118 KG)
153003	ROLL-UP MAT FOR PORTABLE SCALES - ONE PIECE - 33.5" X 118" X 1.5" (850 X 3,000 X 40 MM)	90 LB (45 KG)
100480	CHARGER FOR WHEEL LOAD SCALE (1 SCALE UNIVERSAL) 100-240 VAC - 12" (3.5 M)	2 LB (1 KG)
100492	CHARGER FOR WHEEL LOAD SCALE (2 SCALE UNIVERSAL) 100-240 VAC - 12" (3.5 M)	2 LB (1 KG)
330158	BATTERY STICK (4) AA NIMH	2 LB (1 KG)
750501	CERTIFICATE OF CALIBRATION	



Axle Load Scales

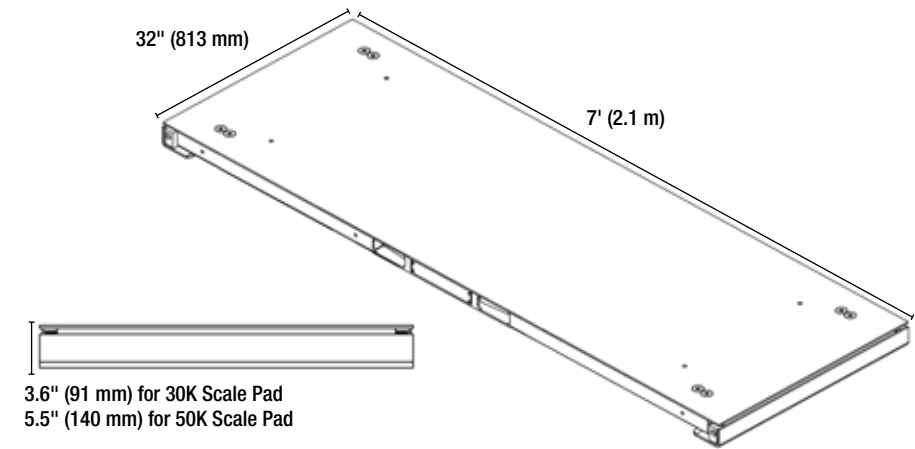

AX900 Axle Load 7' Scales

PART #	DESCRIPTION		CAPACITY/GRADUATION	SHIPPING WEIGHT
160015-RFX	AX900 WIRELESS ALUMINUM AXLE SCALE 7' (60K)	NTEP CLASS III	(1 PR) 7'L X 32"W X 3.6"H SINGLE/TANDEM	750 LB (340 KG)
160015-NP	AX900 DIGITAL ALUMINUM AXLE SCALE 7' (60K)	NTEP CLASS III	(1 PR) 7'L X 32"W X 3.6"H SINGLE/TANDEM	750 LB (340 KG)
160015-A-NP	AX900 ANALOG ALUMINUM AXLE SCALE 7' (60K)	NTEP CLASS III	(1 PR) 7'L X 32"W X 3.6"H SINGLE/TANDEM	750 LB (340 KG)
160003	AX900 DIGITAL MILD STEEL AXLE SCALE 7' (60K)	NTEP CLASS III	(1 PR) 7'L X 32"W X 3.6"H SINGLE/TANDEM	1,816 LB (824 KG)
160003-A	AX900 ANALOG MILD STEEL AXLE SCALE 7' (60K)	NTEP CLASS III	(1 PR) 7'L X 32"W X 3.6"H SINGLE/TANDEM	1,816 LB (824 KG)

NTEP 01-053A2 (with PT20™)

AX900 Axle Load 14' Scales

PART #	DESCRIPTION		CAPACITY/GRADUATION	SHIPPING WEIGHT
160005-RFX	AX900 WIRELESS ALUMINUM AXLE SCALE 14' (120K)	NTEP CLASS III	(2 PR) 14' (4-7")L X 32"W X 3.6"H SINGLE THRU QUAD	1,500 LB (750 KG)
160005-NP	AX900 DIGITAL ALUMINUM AXLE SCALE 14' (120K)	NTEP CLASS III	(2 PR) 14' (4-7")L X 32"W X 3.6"H SINGLE THRU QUAD	1,500 LB (750 KG)

NTEP 01-053A2 (with PT20™)

Trailer Dollie/Jack Stand Scales

PART #	DESCRIPTION		CAPACITY/GRADUATION	SHIPPING WEIGHT
160022-RFX	AX900 WIRELESS ALUMINUM FILLING SCALE 3.5' (60K)		(1 PR) 3.5'L X 32"W X 3.6"H SINGLE	350 LB (160 KG)
183015-RFX	PT300HD PORTABLE SCALE (30K X 50)		30,000 X 50 LB (15,000 X 2 KG)	85 LB (39 KG)
183016-RFX	PT300HD PORTABLE SCALE (40K X 50)		40,000 X 50 LB (20,000 X 2 KG)	85 LB (39 KG)

AX900 Axle Load Scale Accessories

PART #	DESCRIPTION		CAPACITY/GRADUATION	SHIPPING WEIGHT
101221-RFX	WIRELESS PT20 CPU			9 LB (9 KG)
800812	AX900 CALIBRATION OF CUSTOMER INDICATOR TO AX900 ONE PAIR OF PLATFORMS (MUST BE SPECIFIED WITH SCALE PURCHASE)			
160308	TRAILER FOR AXLE SCALE SYSTEMS			CALL
750501	CERTIFICATE OF CALIBRATION			
183004	DIRECT POWER CABLE FOR AX900 WIRELESS SCALES 50' (15 M)			5 LB (2 KG)
160085	CABLE, AX900 INTERCONNECT, QUICK DISCONNECT 15' (4.5 M)			2 LB (1 KG)
160089	CABLE, PT20 TO AX900 INTERCONNECT 50' (15 M)			5 LB (2 KG)
189009	CABLE, INTERCONNECT/CHARGE, 2 WHEEL SCALE TO PT20			2 LB (1 KG)



Accuracy of ±0.1% of Reading

60,000 lb (30,000 kg) to 180,000 lb (80,000 kg)
System Capacities

RFX® Wireless Digital Scales: Cable-Free
Digital Scales for Efficiency & Safety
Analog Scales: Calibrate Scales to Most
Industry Indicators

Aluminum or Steel Construction

Modular Design to Accommodate
Multiple Axle Configurations

Low-Profile Height:
3.6" (91 mm) for 30K Scale Pad
5.5" (140 mm) for 50K Scale Pad

Ramps Measure 18" (457 mm)

Commercially-Available D Alkaline Batteries
Last up to 300 Hours in Scales

Low-Profile Weighbridges in a Variety of Lengths

Rugged AX900™ weighbridges are available in a variety of lengths, capacities and configurations to weigh anything from single to multi-axle vehicles in locations where permanent scale installations are not feasible. Cable-free operation is made possible with RFX® Wireless Weighing communication back to a variety of devices, while digital output still allows for cable backup. The AX900™ series utilizes stainless steel shear beam load cells to weigh loads up to 180,000 lb (80,000 kg) with an accuracy of ±.1%.

Compatible with a variety of Intercomp devices, see pages 12.

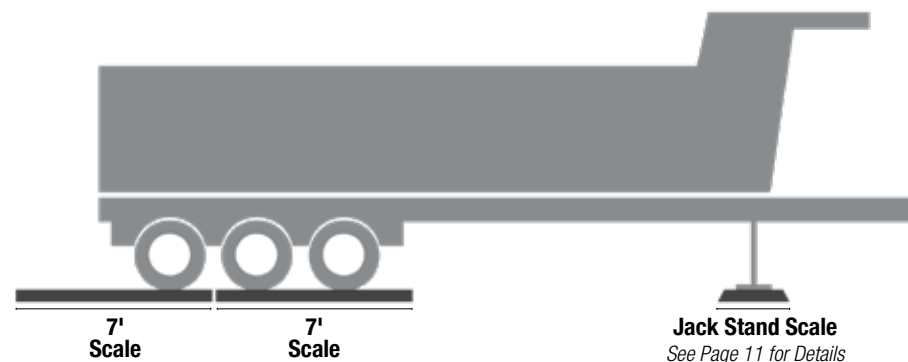

INDICATORS & SOFTWARE



HH60™ Handheld Indicator



HH400™ (IWH) RFX™ Indicator



PT20™ CPU



TS30™ CPU Touchscreen



IntercompWeigh™ Software



iExactWeigh™ & iVehicleWeigh™ Apps

NUMBER OF SCALES	6	4	2-12	2-12	32	2- 10 or 12
BATTERY TYPE	Standard AA	Standard AA	D-Cell NiMH	Lithium	n/a	n/a
BATTERY LIFE	Up to 40 Hours	Up to 40 Hours	Up to 40 Hours	Up to 12 Hours	n/a	n/a
DISPLAY	20-Digit, 4 Row LCD	Graphic LCD	LCD	Touchscreen	n/a	n/a
READ ONLY MODE	●	●	●			●
VEHICLE/USER INFORMATION FIELDS			●	●	●	●
TIME/DATE STAMP			●	●	●	●
WEATHERPROOF/WATERPROOF		IP65	IP67 Closed, IP52 Open & Operational	IP67 Closed, IP52 Open & Operational		

CONTROLS:

CONTINUOUS SERIAL OUTPUT	●	●	●	●		
CALIBRATE	●	●	●	●	●	
ON/OFF	●	●	●	●	●	●
ZERO SCALE(S)	●	●	●	●	●	●
ON-DEMAND PRINTING	●	●	●	●	●	●
TARE	●	●	●	●	●	●
PEAK	●	●			●	
LB/KG	●	●	●	●	●	●
BLUETOOTH® OUTPUT TO MOBILE iOS	●					

SCREEN VIEWS:

INDIVIDUAL WEIGHT	●	●	●	●	●	●
GROSS/NET/TARE	●	●	●	●	●	●
AXLE GROUP	●		●	●	●	●
ACCUMULATIVE TOTAL	●	●	●	●	●	●
CENTER OF BALANCE	●		●	●		
TARE	●	●	●	●	●	●

info@intercompcompany.com
Worldwide: +1 763-476-2531
Toll Free: 800-328-3336

© 2020 Intercomp Company



Specifications subject to change without notice.



Printed in the U.S.A.

700734